



NX Profile Series Assembly Manual



Designed by Jim Vigani
Version 1.1 – 8/1/09



A Tech Hobbies, LLC Company

532 North Avenue
Dunellen, New Jersey 08812

Ph: (732)424-6400

Website: www.airfoilz.com

e-mail: info@airfoilz.com

© Copyright 2009 all rights reserved

Limited Warranty

AirfoilZ takes pride in the care and attention given to the manufacture of the components in this kit. The company warrants replacement of any materials found to be defective for their intended use prior to their use in the construction of the model, provided the purchaser requests such replacement within a one year period from the date of purchase, and the part is returned, if so requested by the Company. No other warranty, expressed or implied, is made by the company with respect to this kit. The purchaser assumes full responsibility for the risk and all liability for personal or property damage or injury resulting from the purchaser's use of the components of this kit whether assembled or not.

The Company reserves the right to provide a full refund to the purchaser if the model does not perform as advertised. Any refund is at the sole discretion of the Company.

Introduction:

Thank you for choosing one of the AirfoilZ NX Profile Series airplanes. We have taken great care to provide a design and kit components that, when properly assembled, will give you a high quality model with outstanding performance. While the assembly is not complicated, the quality and ultimate performance of your model will depend on the care you take while building. **Please read these instructions carefully and be sure that you understand them before you start.** Take care to assemble the components as shown and in proper alignment.

Please note that the material used for some of the parts shown may be different in from those provided in the kit. The installation of these parts is unaffected by the material change.

Warning

This radio-controlled model is not a toy and, if operated inappropriately can cause serious bodily injury and property damage. It is the buyer's responsibility to assemble the kit correctly and properly install the motor, radio and all other equipment. The model must always be flown in accordance with the safety standards of the Academy of Model Aeronautics (AMA).

*This model is designed for high performance. While it is reasonably simple to assemble, it is not intended for the novice flier. **Do not attempt to learn to fly with this model!** If you are an inexperienced modeler, we recommend that you get the assistance of an experienced modeler to help you with the assembly and initial flights. There are many local clubs that can offer help with assembly and flight instruction. Information on local clubs can be found through the Academy of Model Aeronautics. The AMA has over 2500 chartered clubs throughout the country. Information on the AMA can be found at www.modelaircraft.org.*

We do not recommend the use of hot glue for mounting components such as servos, control horns, receivers or speed controls.

Recommended Power System:

This plane has been designed to use a 175 to 250 watt power system. Recommended motors include the Common Sense E5 -L -13, Hacker A20-20L, Scorpion 2215-18, or AXI 2217-16. The prototype was flown with the with the Common Sense E5-L-13. a 25-amp Pheonix ESC, and a 1500 mAh, 3S Li-poly battery with a APC 10x5Epropeller. Other power systems with similar capabilities can be used. Performance will vary depending on the specific power system selected. For information on alternate power systems please visit <http://3dxhobbies.com> or your local hobby shop.

Kit Contents:

Before you start the assembly of this model, check to make sure that there are no missing parts and that none of the parts have been damaged during shipment. If you have any questions with the assembly or flying of this model, please contact us and we will be happy to assist you. If you need replacement parts please provide the model name. The parts included in the kit are shown on the Part Sheet included with the kit.

Other items you may need that are not included with your kit:

Building Supplies:

In addition to the kit contents, we recommend having the following building supplies on hand to complete the kit assembly in accordance with this manual.

- Foam safe (odorless) CA
- Foam safe CA "Kicker"
- Gorilla glue
- 5, 15, and 30 minute epoxy
- Double back tape or spray adhesive
- Low tack masking tape (blue painter's tape)
- Sanding block with 100 grit sandpaper
- Sanding stick or emery board (150 grit)
- Soldering iron and resin core solder
- $1/32$ inch and $1/16$ inch diameter drill bits
- Exacto knife with #11 blade
- Utility knife
- Small square
- 36 inch ruler
- Needle nose pliers
- $3/8$ inch diameter brass tubing
- Diagonal cutting pliers

Power and Control Equipment:

The following items are needed to provide power and control function to your model.

- Brushless outrunner motor with radial mount
- 4 motor mounting screws
- Brushless motor speed control
- 4 micro servos (Hitec HS-55 or equivalent)
- 3S Li-poly battery pack
- LI-poly battery charger
- 4 or 6 channel micro receiver
- Y harness if a 4 channel receiver is used
- 3 to 6 channel transmitter

Making a Sanding Block:

The leading edges of the elevator, the rudder, and both ailerons need to be beveled prior to installing the hinges. This is best performed by the use of a 2-inch wide by 12 inch long, 100 or 120 grit sanding block or sanding bar. In addition, other areas of the airframe need to be sanded as shown in this manual to complete the assembly and enhance appearance. If you do not have a suitable sanding block, one can be easily made by securing a piece of 100 grit sand paper to a 2 inch x 12 inch x $\frac{3}{4}$ inch wooden block. The sandpaper can be secured to the block using either double backed tape or spray adhesive. ***Make sure that the block is flat!*** A styrofoam block is great for general sanding of the fuselage and non-beveled edges of the control surfaces.

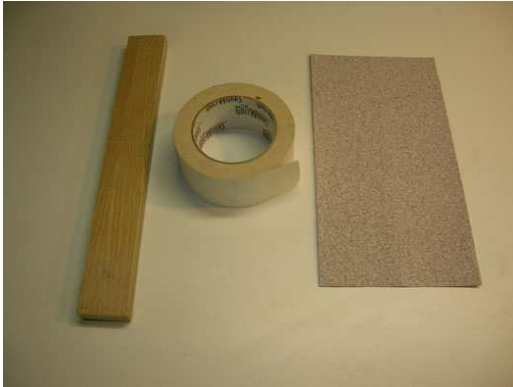

Figure: 1



Figure: 2



Figure: 3

General Comments on Assembly:

While not difficult to assemble, the AirfoilZ NX Profile Series kits are intended for persons with some building experience. As such, the instructions are presented as a simple sequence that, when followed, will help ensure that the airframe turns out straight and light. Improperly aligned surfaces and unnecessary weight will only hinder its performance. Apply glue and epoxy in a thin uniform coat, using only enough to achieve a strong bond. Excess glue or epoxy will only add unnecessary weight and will not increase the strength of your model. Trial fit all components to ensure fit and alignment before applying any glue or epoxy. Keeping joints tight fitting will minimize the amount of glue required and will ensure a strong bond. Use a light touch while sanding. Foam cuts very

quickly and excess pressure can limit your ability to accurately shape the foam. Take extra care not to over sand. Avoid scratching the surface of the Depron foam.

Graphics:

The AirfoilZ NX Profile Series kits come with printed vinyl graphics. Extra care in cutting out and applying the vinyl panels will result in a professional look for your plane. Some people prefer to lightly mist the surface with “Frebreze” before applying the vinyl. This allows the vinyl to be repositioned while applying them.

Fuselage Assembly:

The fuselage assembly on the AirfoilZ NX Profile Series kits consists of two routed depron skins, laminated over a carbon tube and a balsa spar.

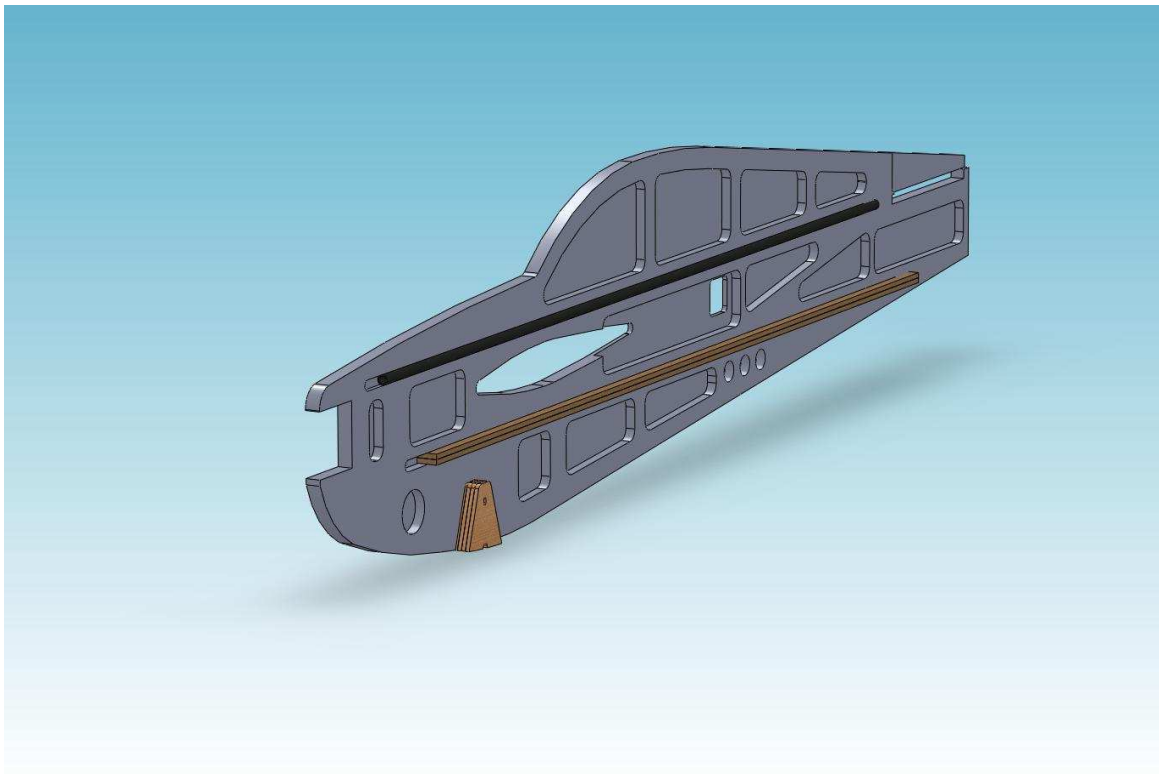

Right Fuselage Skin with Spars and Landing Gear Mount

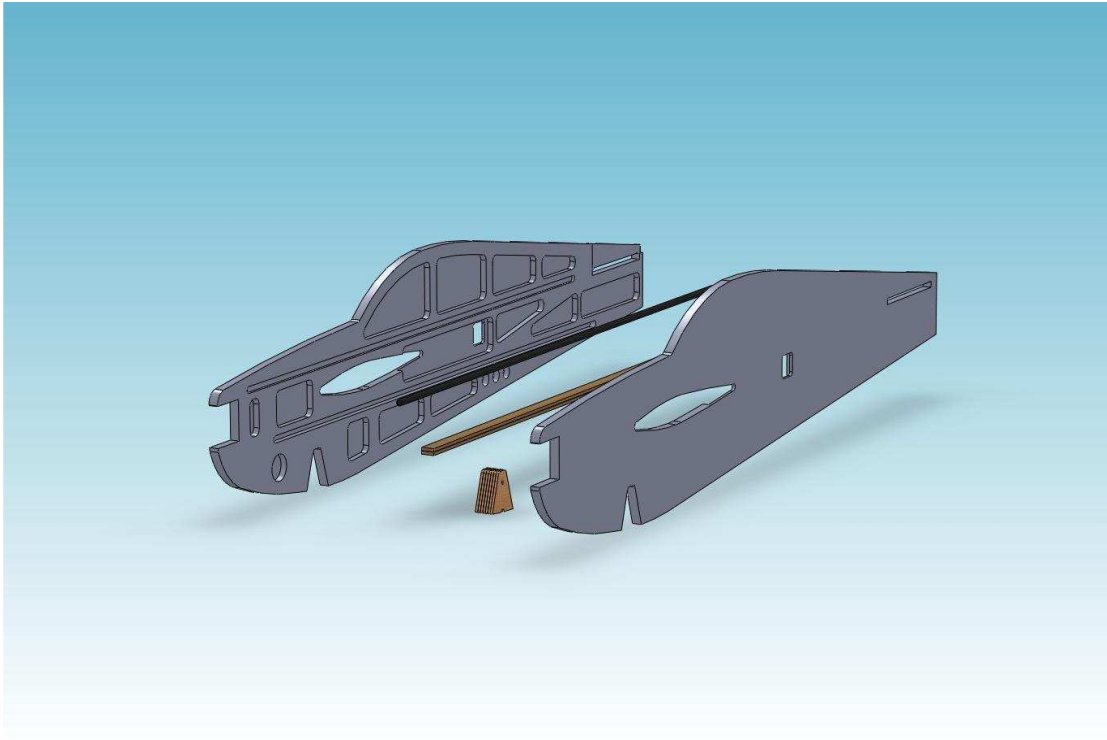

Fuselage Assembly - Exploded

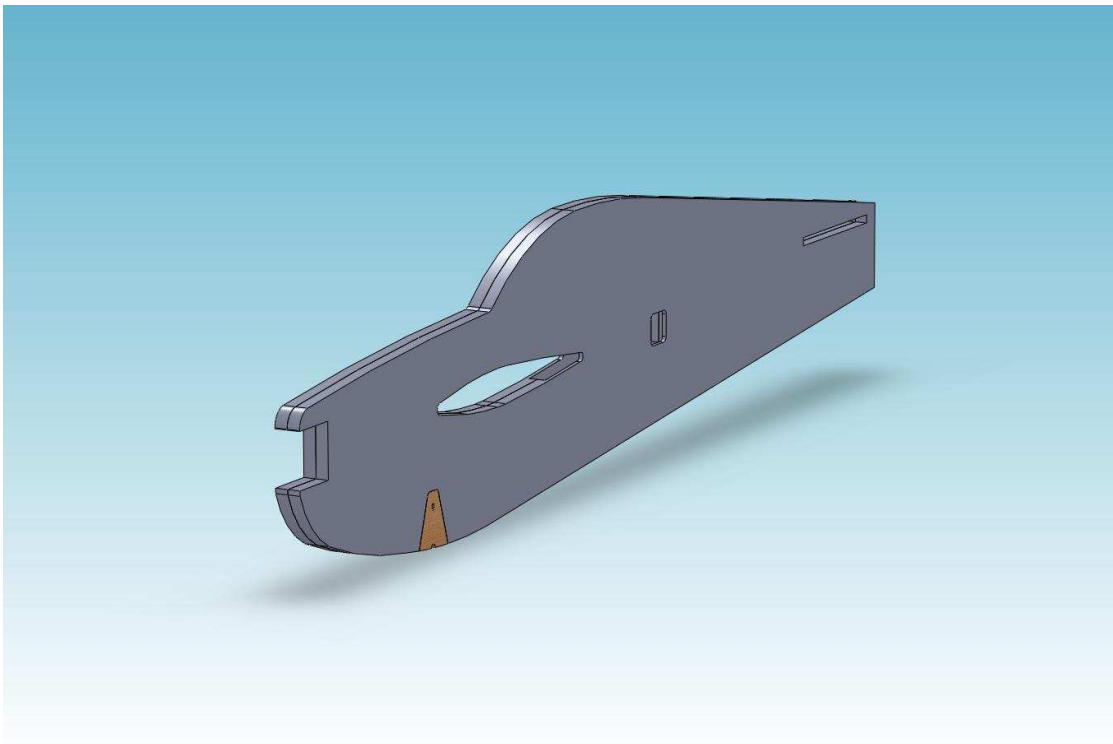

Fuselage Assembly

Follow the steps in the order outlined below to ensure accurate alignment of the components.



Step 1

Glue the two 1/8"x 1/2"x 24" balsa spars together to form a single spar measuring 1/4"x 1/2"x 24". Check that the spar edges are straight. If slightly bent, lightly sand the edges as required to eliminate the bend.

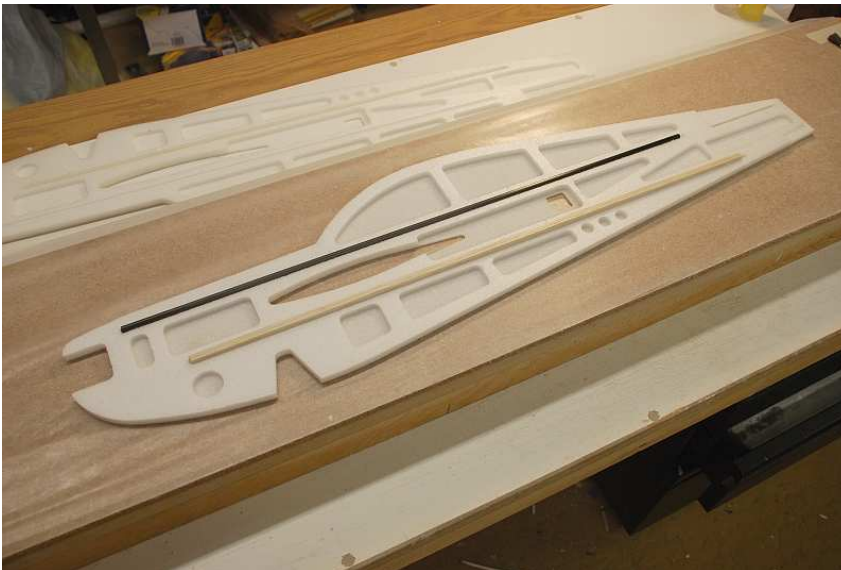

Step 2

Test fit the carbon tube and balsa spar in their respective grooves.



Test fit the other skin over the spars and check that both skins touch without any gaps.



Step 3

Glue the fuselage spars and skins together using 30 minute epoxy or a very thin layer of Gorilla glue. **NOTE:** Place the glued assembly on a flat building surface and weigh down to ensure the assembly dries flat and true.

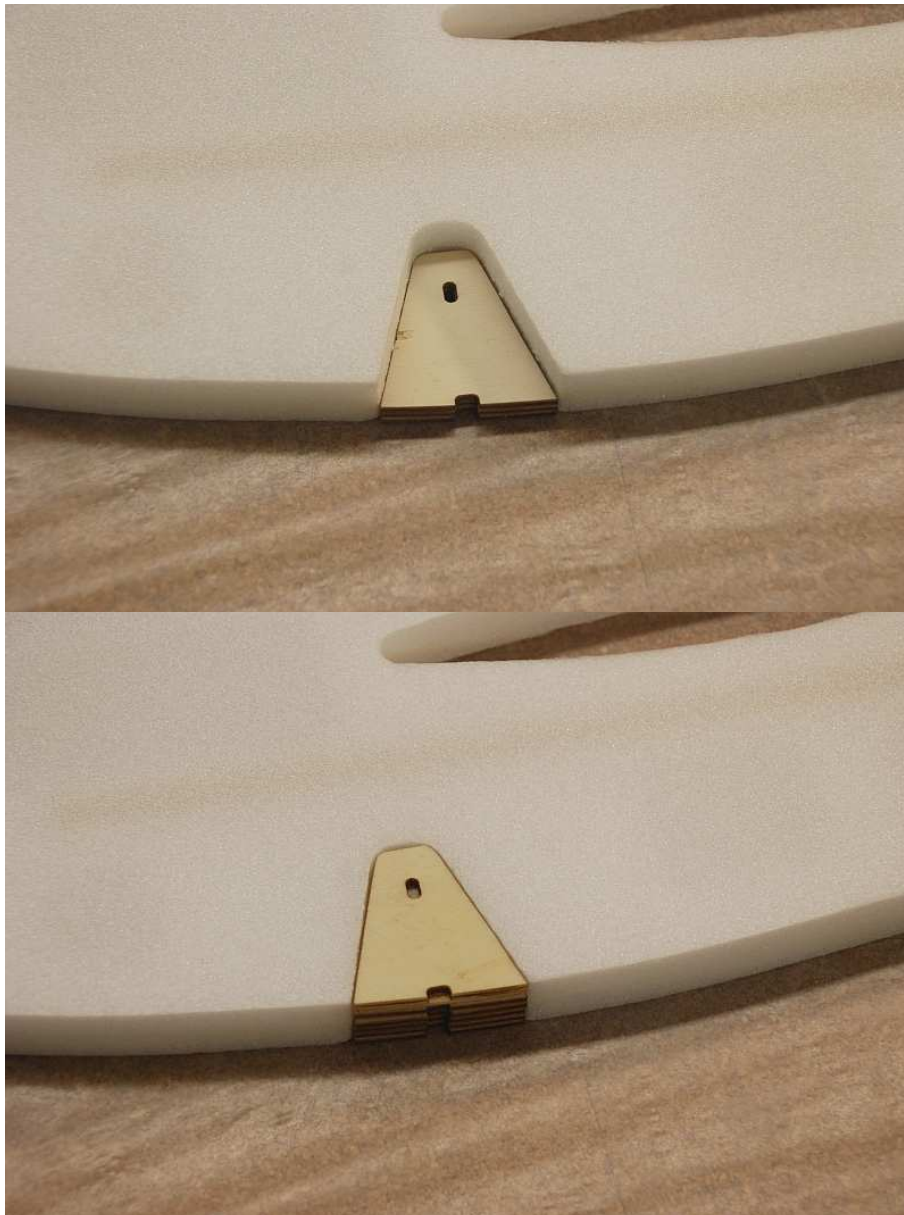

Step 4

Using the fuselage cutout as a guide, glue the stack of landing gear mount plates together with CA to form the landing gear block. If necessary, sand the block to the thickness of the fuselage. **Do not glue the blocks to the fuselage.**

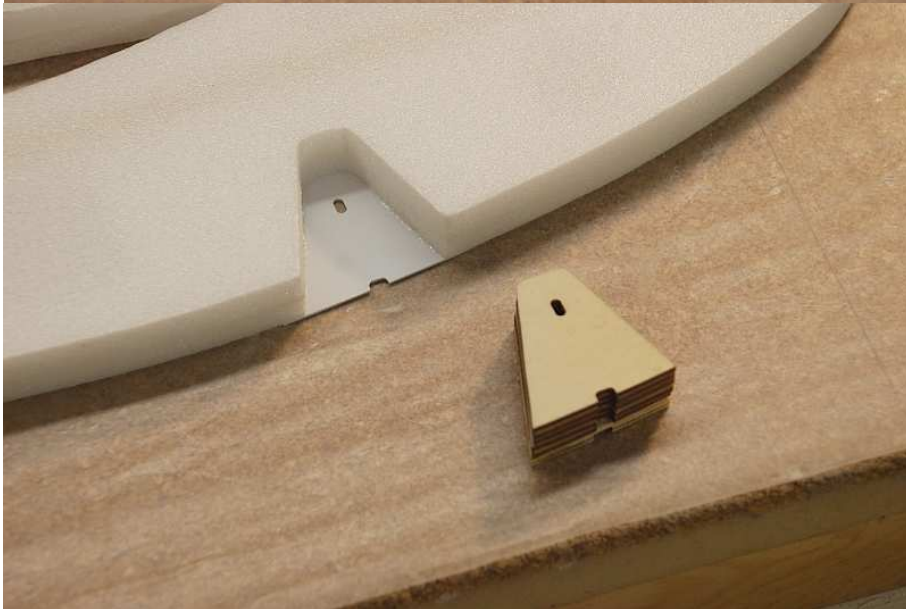

Step 5

Glue one of the plastic landing gear mount doublers to the side of the fuselage with foam-safe CA. Epoxy the landing gear block and other plastic landing gear mount doubler in place with 5 minute epoxy. **Tip: Sand the surface of the plastic landing gear mount doublers that mates to the fuselage for better bonding of the glue.**



Step 6

Glue the plastic nose doublers in place with foam-safe CA making sure to align the edges of the doubler with the opening in the fuselage. **Tip: Sand the surface of the plastic nose doublers that mates to the fuselage for better bonding of the epoxy.**

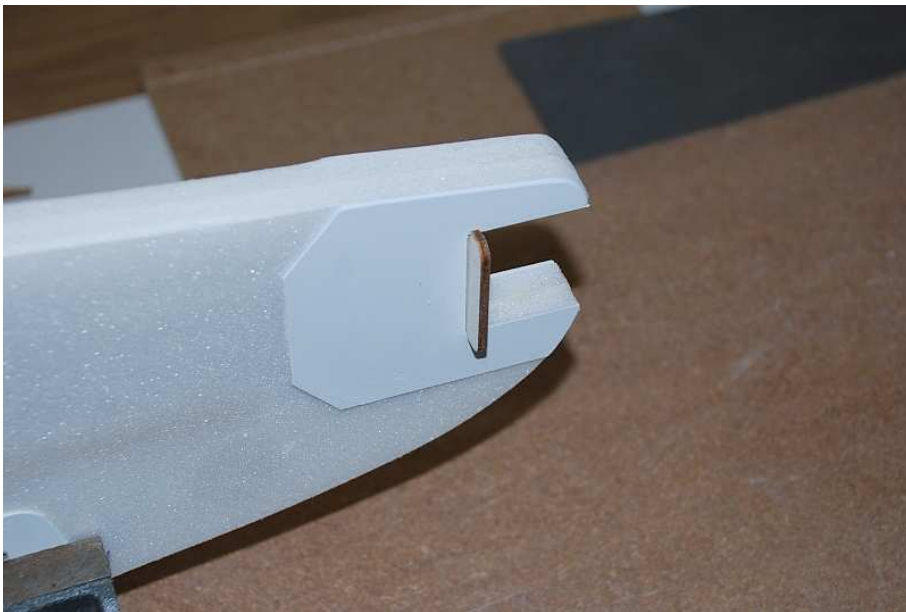

Step 7

Test fit the ply motor mount in the fuselage opening.



Cut the balsa tri-stock motor mount supports to the proper length and check their fit behind the motor mount. Epoxy the motor mount and balsa tri-stock rear supports in place making sure that the motor mount is square to the fuselage. **Tip: lightly sand the plastic doubler for a better bonding of the epoxy.**

If you would like to finish the edges of the fuselage, do that after the motor mount and the landing gear mount have been installed. Use your sanding block to smooth and either bevel or round the edges approximately $\frac{1}{8}$ inch. Sand the edges of the motor mount and motor mount supports smooth using the sanding stick or emery board.

Wing Assembly and Installation

Assembling the Spar:



Step 8

Glue the spar web to the center of the bottom spar cap with thin CA being sure to keep the spar web perpendicular to the spar cap.





Step 9

Repeat for the top spar cap forming the "I beam" shape. **Tip:** When completed, lightly sand the spar edges to help it slide into the wing.

Wing Assembly:

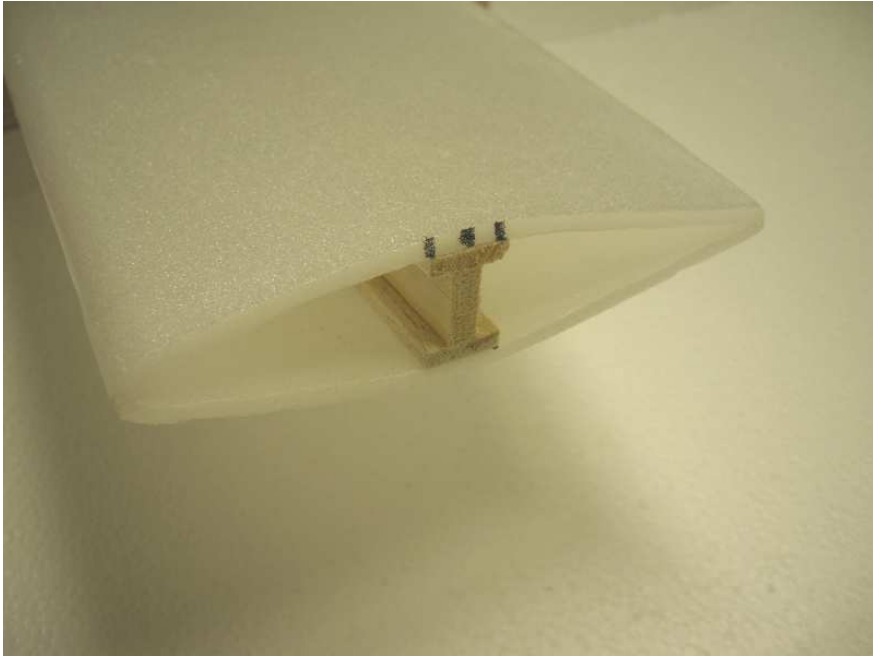

Step 10

Using the distance from the table below, place a mark spar location mark behind the leading edge at each wing tip. Place another mark behind the leading edge at each wing root.

Model:	Tip Distance:	Wing Root Distance:
Extra 300NX	2 1/8"	3 1/8"
Edge 540NX	2"	2"
Yak 54NX	2 1/8"	3 1/8"

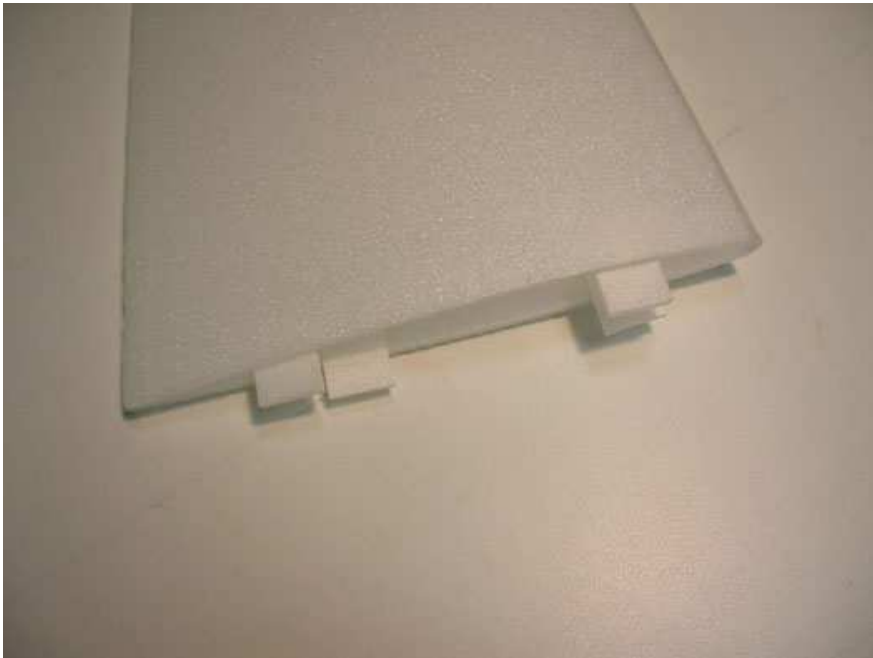

Step 11

Glue the 3 mm foam wing alignment tabs in place on the left wing using foam safe CA staying sufficiently away from the spar location mark to allow room for the spar.

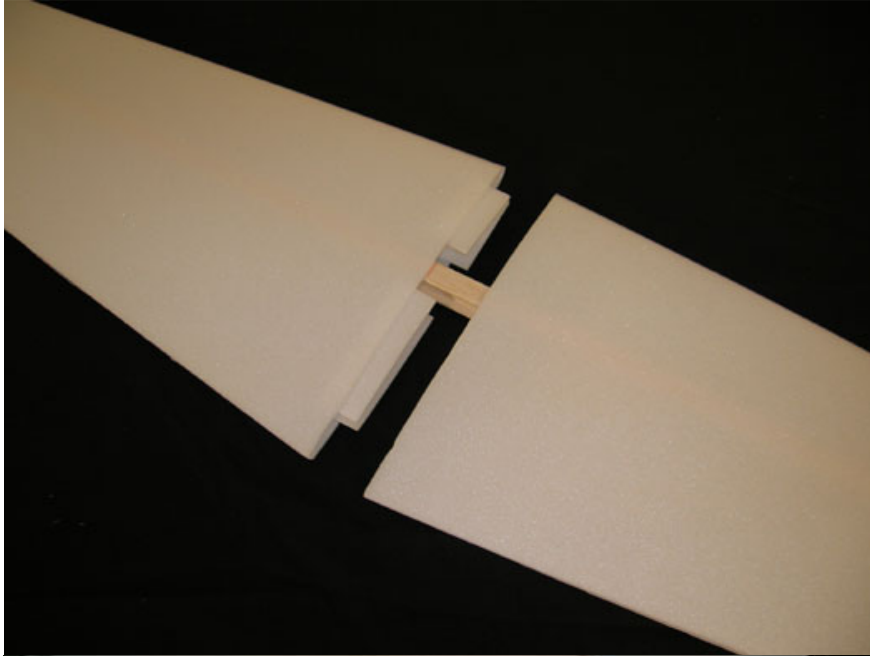

Step 12

Mark the center of the spar and test fit it in the wings. Glue the spar into place with Gorilla Glue or 15-minute epoxy. Align the spar with the spar location marks on the wing panels.



Step 13

Repeat for the other wing making sure to align the root sections at the center seam. Apply the epoxy to the center seam after sliding the second wing on the spar, just before the two wings are pushed together.



Step 14

Push the wing center joint together making sure the wing root airfoil profile of both wings match at the center.



Step 15

Carefully sand the wing tip profile and spar end to remove any irregularities. Glue the wing tip caps onto the wing using foam safe CA and foam safe kicker. For curved wing tips, carefully bend the wing tip caps around the bend.





Step 16

Trim and sand the wing tip to final shape.



Wing/Fuselage Assembly:



Step 17

Test fit the wing in the fuselage. **DO NOT FORCE!** If the fit is tight, gently sand the fuselage opening to fit. Make sure the wing is centered on, and square to the fuselage. With the wing properly aligned, tack glue it in place with medium foam safe CA.



Step 18

Permanently glue the wing in place by forming a fillet from mixture of 15 or 30-minute epoxy and micro balloons.

Tail Feather Assembly and Installation:

Installing the Elevator Joiner:

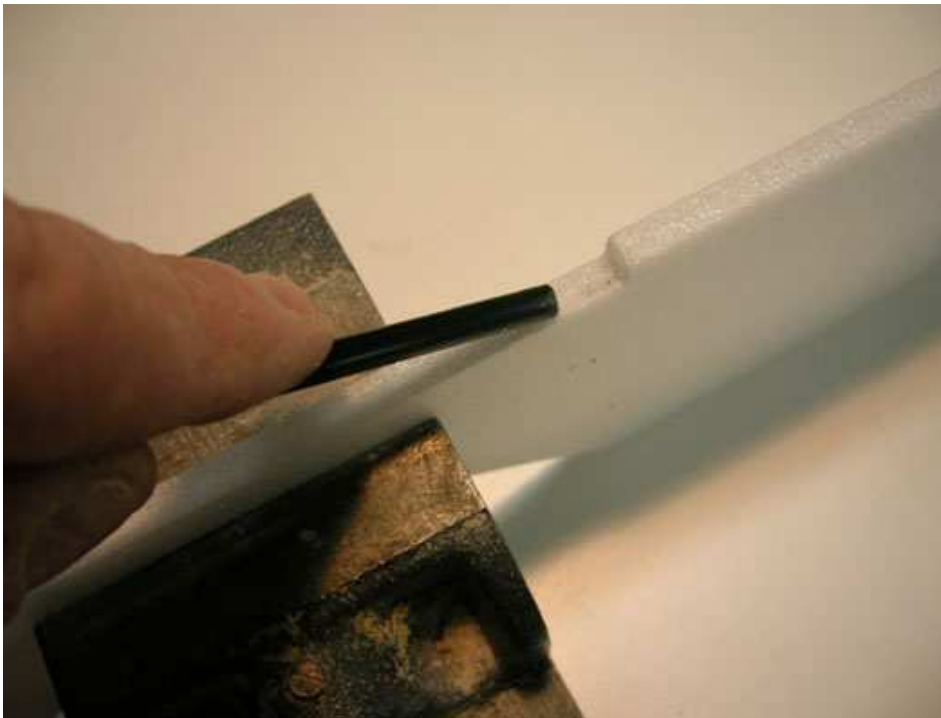

Step 19

Using the end of the 3/16" diameter carbon elevator joiner, gently create a shallow groove in the elevator joiner cutout.



Step 20

Secure the 3/16" diameter carbon elevator joiner in place with epoxy. **Tip: For a lighter joint, a mixture of 15 minute epoxy and micro balloons can be used.**



Step 21

Cut out the foam bridge behind the wood joiner, between the elevator halves.

Installing the Horizontal Stabilizer Spar:

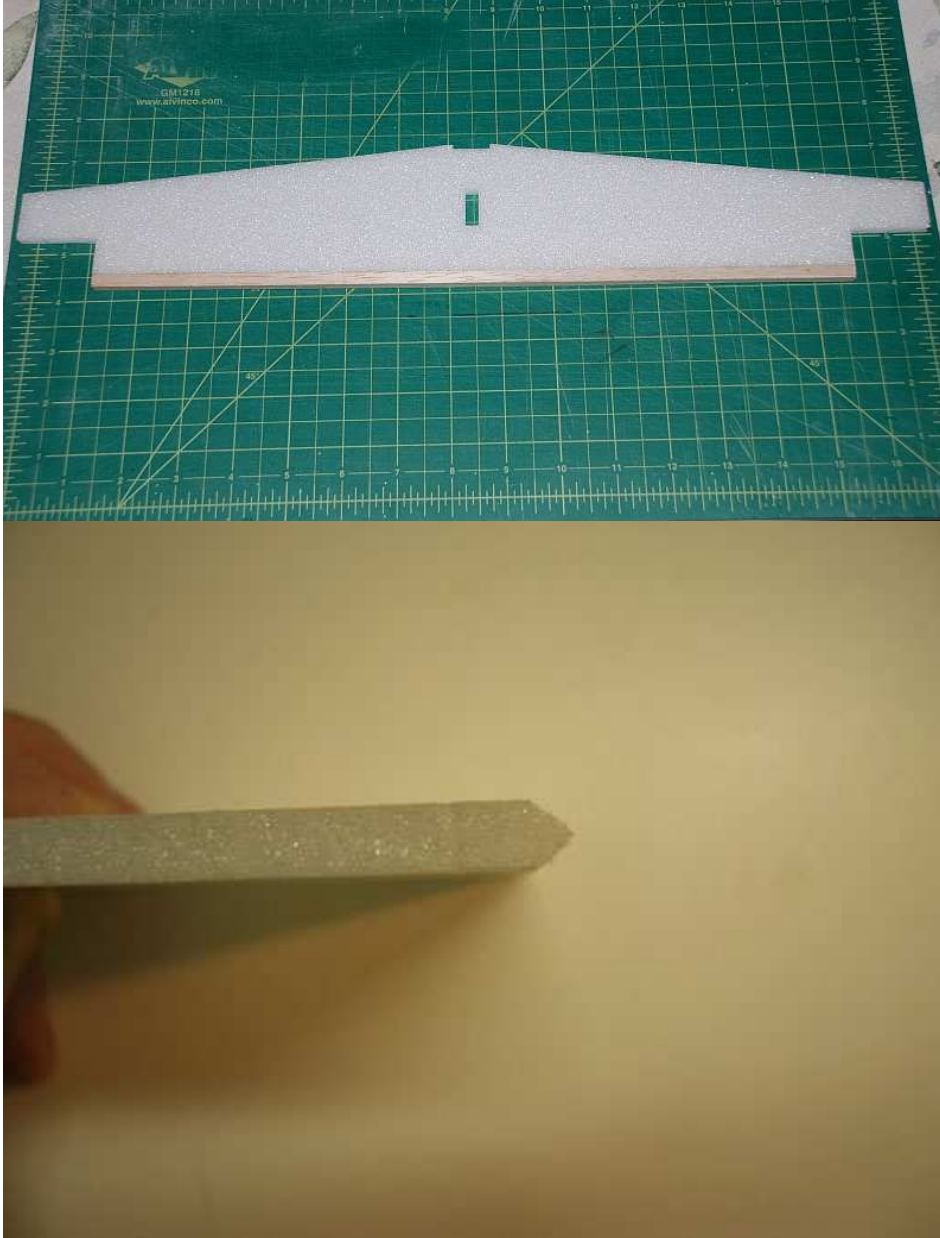

Step 22

Glue the $\frac{1}{4}$ "x $\frac{1}{4}$ " balsa horizontal stabilizer spar to the rear of the horizontal stabilizer

Step 23

Using the sanding block, bevel the leading edge of the elevator as shown to allow for movement of the elevator when hinged.

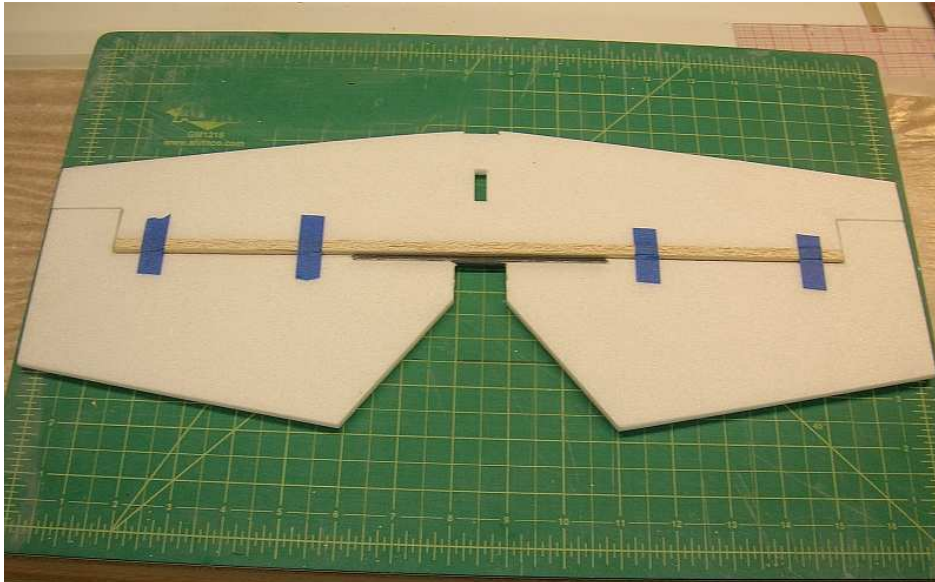

Step 24

Temporarily secure the elevator to the stabilizer with tape. Mark the position of the elevator hinges with strips of $\frac{3}{8}$ " wide painter's tape. Use 3 hinges on each side of the elevator.

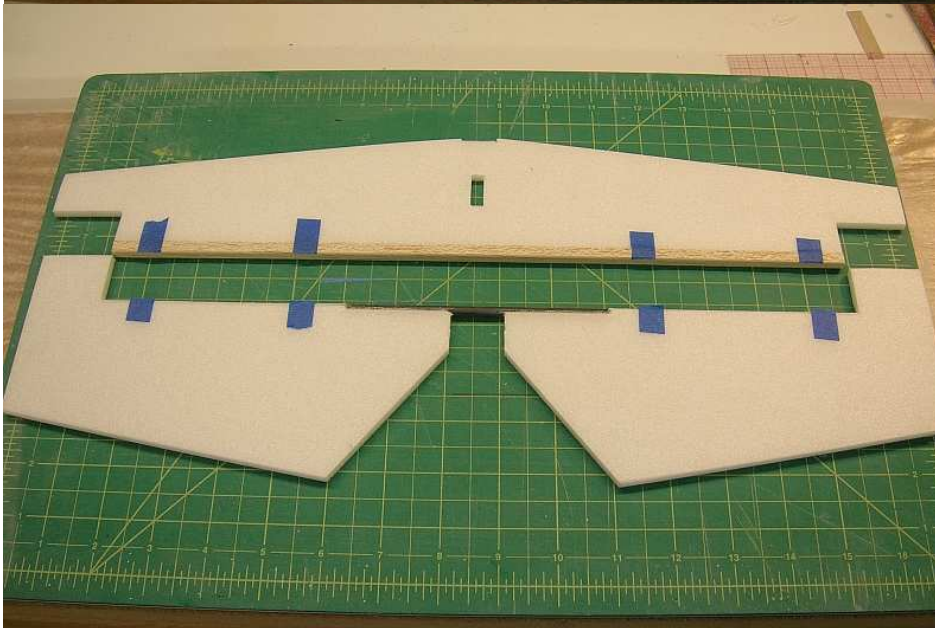

Step 25

Cut the tape along the hinge line and remove the elevator.



Step 26

Using your Exacto knife, carefully cut a slit along the centerline of both the stabilizer and elevator at each hinge location. Test fit the hinges into the slits. **NOTE: Do not glue the hinges in place at this time.**

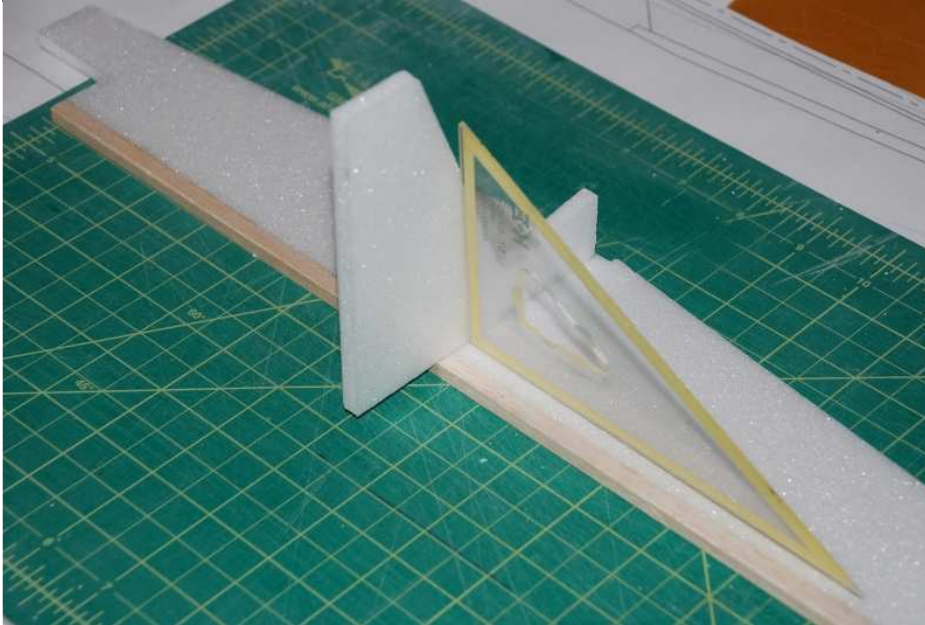

Step 27

Glue the vertical Stab to the horizontal stab making sure the parts are square.

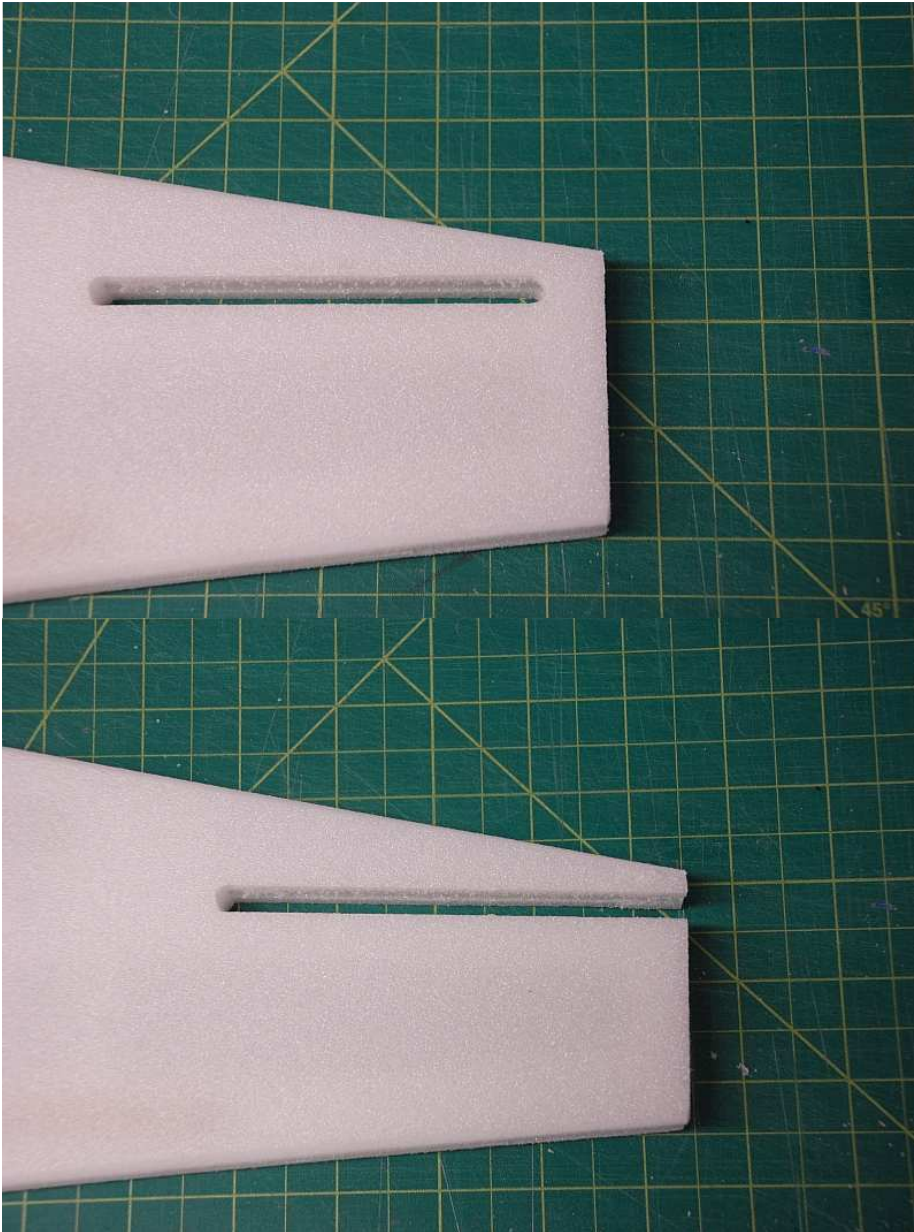

Step 28

Trim the rear of the horizontal stab slot in the fuselage.

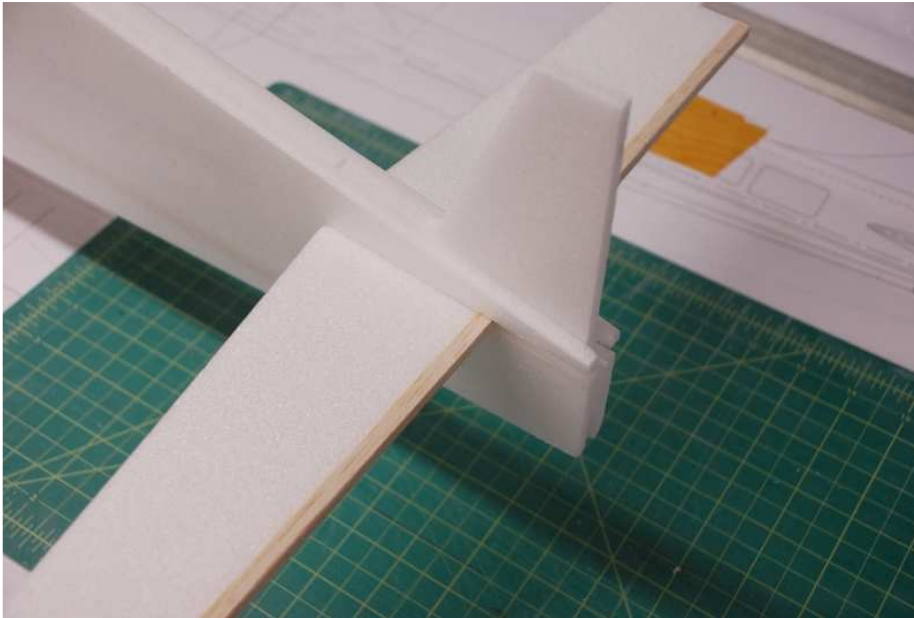

Step 28

Test fit the horizontal and vertical stabilizer assembly in the fuselage and check that it fits square to the fuselage and wing. Glue the stabilizer in place with medium foam safe CA.

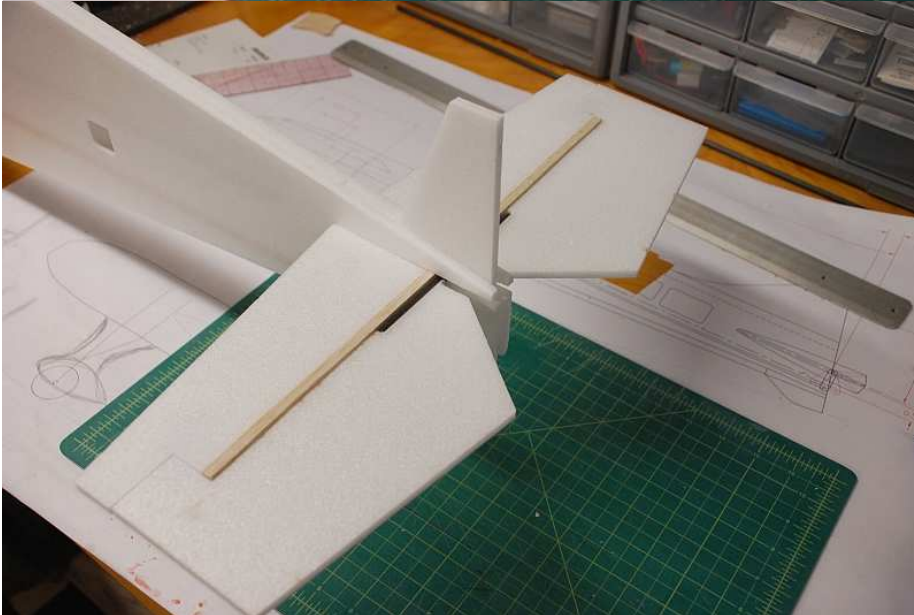

Step 29

Install the elevator and epoxy the hinges in place.

Rudder Installation:

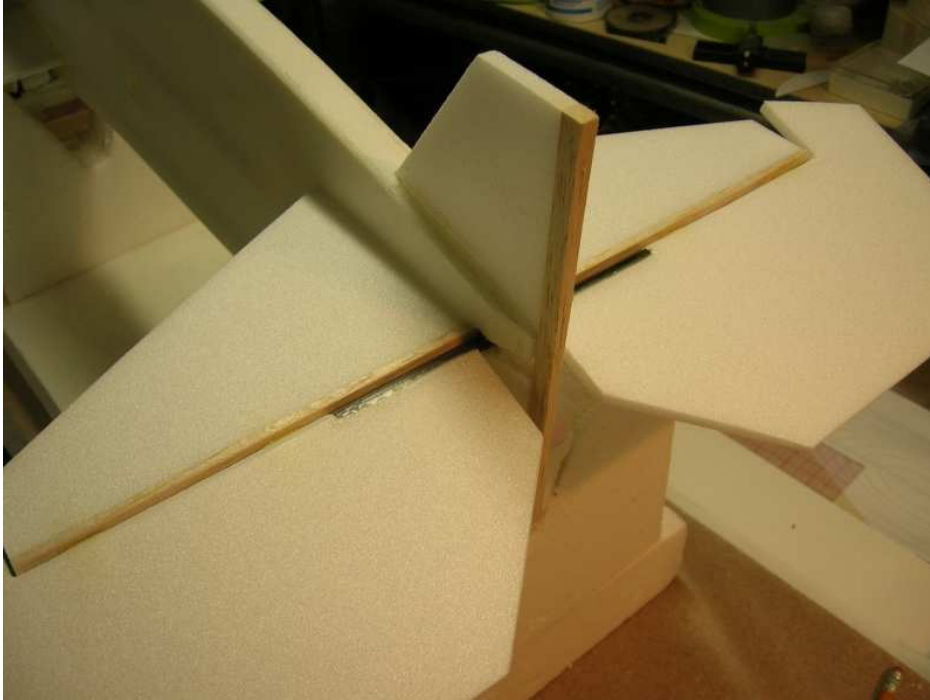

Step 30

Glue the rudder post in position using foam safe CA. Sand the rudder post flush with the top of the vertical stabilizer and with the bottom of the fuselage. Trim the back of the fuselage at an angle to match the rudder post using your Exacto knife. This allows clearance for the rudder control horn.

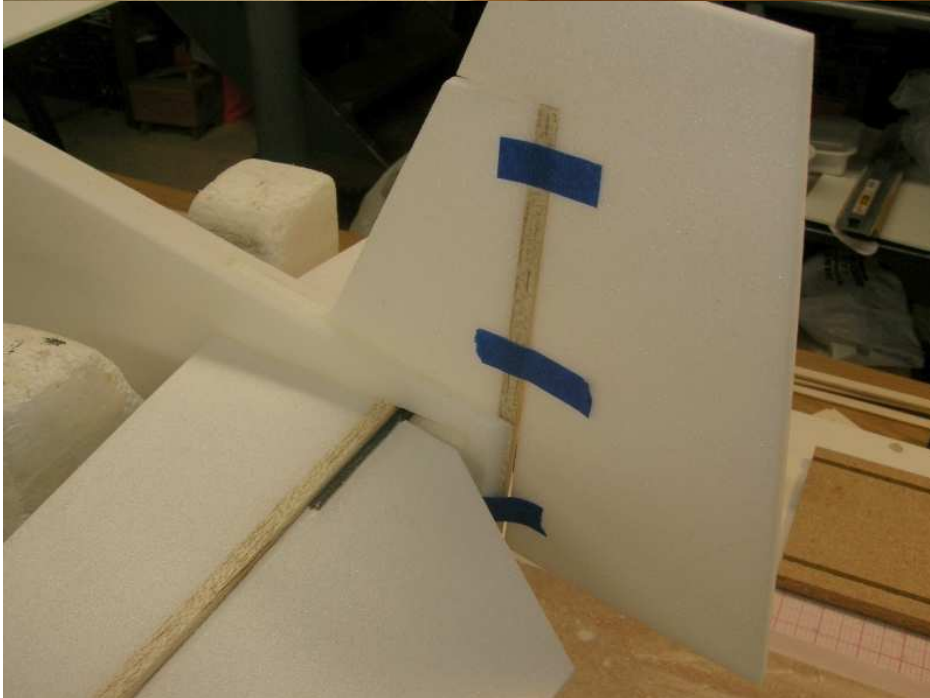

Step 31

Bevel the leading edge of the rudder and install using the same method as with the other control surfaces. Use 3 hinges. Remember to leave approximately $\frac{1}{32}$ " clearance between the top of the vertical stabilizer and the rudder.



Aileron Installation:



Step 32

Using the sanding block, bevel the leading edge of the ailerons as shown to allow for movement of the ailerons when hinged.

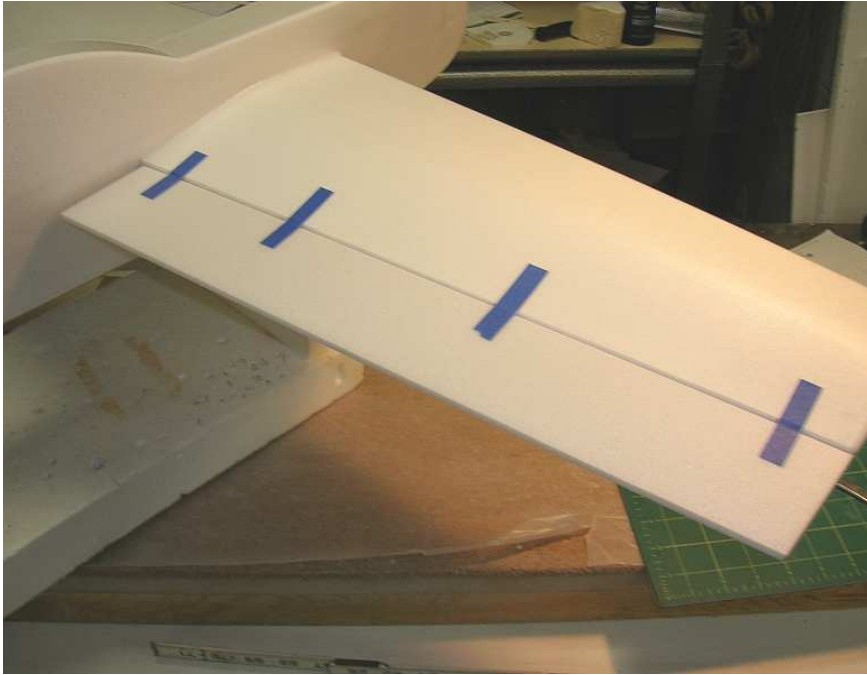

Step 33

Temporarily secure the ailerons to the wing with tape. Mark the position of the aileron hinges with strips of $\frac{3}{8}$ " wide painter's tape. Use 4 hinges for each aileron.

Note: To minimize aileron flexing, position the centerline of the second hinge approximately $5\frac{1}{2}$ " from the side of the fuselage, near the location where the aileron control horn will be located.

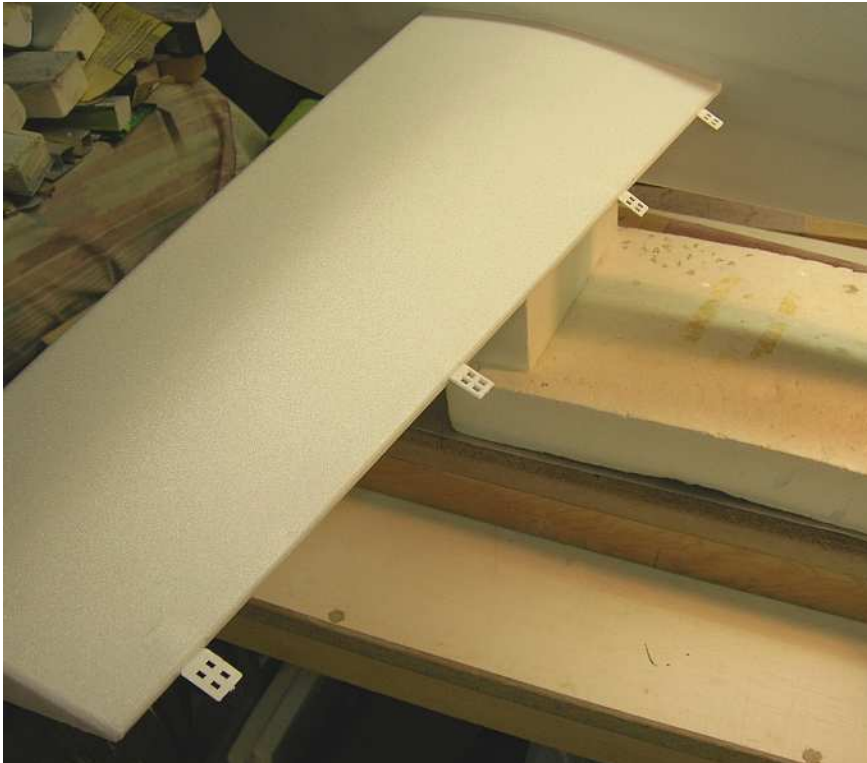

Step 34

Cut the tape along the hinge line and remove the ailerons. Using your Exacto knife, carefully cut a slit along the centerline of both the aileron and the wing trailing edge at each hinge location and glue the hinges in place

NOTE: that the wing has a glue seam along the centerline of the trailing edge. Make all the slits in the wing trailing edge as close as possible to the centerline, directly above the glue seam!

Aileron Servo Mount Installation:

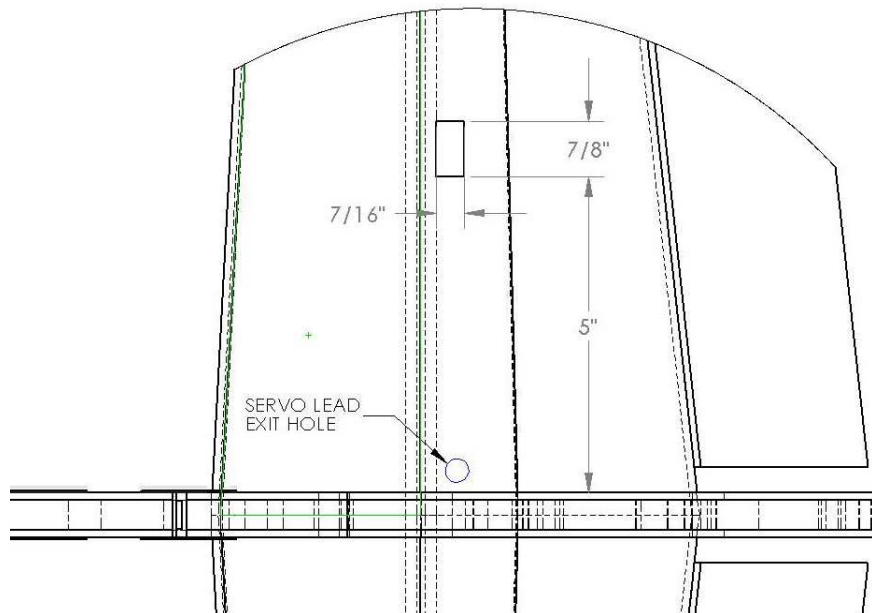

Step 35

Mark the wing servo locations on the bottom surface of the wings. The recommend servo location using Hitec HS-55 or HS 65 servos is shown. Cut the hole in the wing skin for the servo using your Exacto knife. Cut the servo lead exit hole location being careful to avoid cutting into the wing spar.



Step 36

Test fit the servos in the holes. Mark the location of the servo mounts and remove the servos. Glue the servo mounts in place with foam safe CA. Drill a 1/32 inch diameter pilot hole in the servo mounts at each servo mounting lug location.

Typical Control Horn Installation:

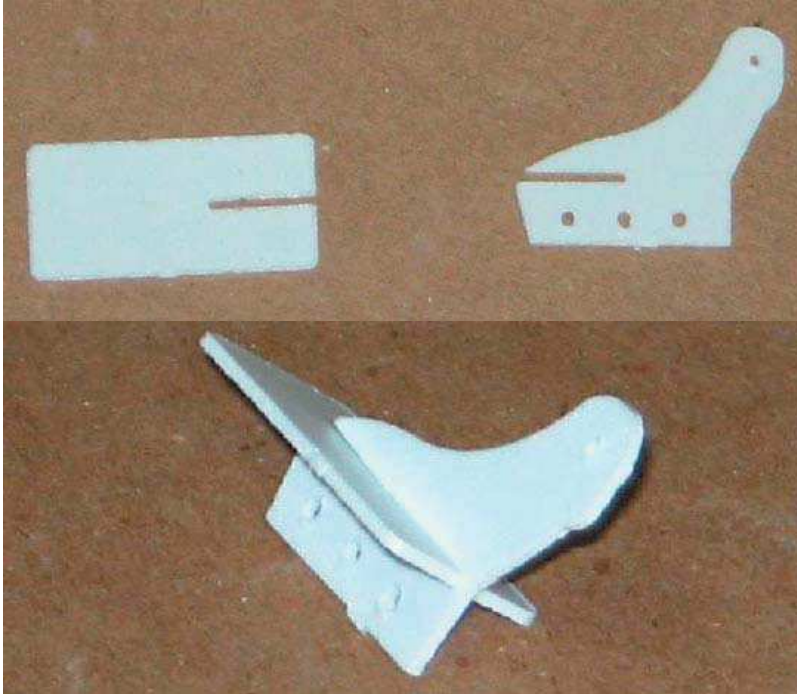

Step 37

Sand the edges of the plastic control horn parts to remove the edge caused by the laser cutting. Test fit the pieces together



Step 38

Mark the location of the control horns on the control surface and cut a slit in the control surface with an Exacto knife to accept the control horn mounting tab.



Step 39

**Glue the control horns
in place with medium
foam safe CA or Epoxy.**

Landing Gear Installation:



Step 40

Solder a #2 washer on the landing gear as an inner wheel retainer. **Tip: Drill a 3/32" hole in a scrap block of wood to use as an alignment tool. Lightly sand the axle and washer to ensure good bonding of the solder.**



Step 41

Place a scrap piece of thin plywood or cardboard over the wheel as a spacer and slide a #2 washer on the axle. Solder in place.

Use only enough heat to ensure good solder flow. Excess heat may melt the wheel hub.



Completed wheel installation

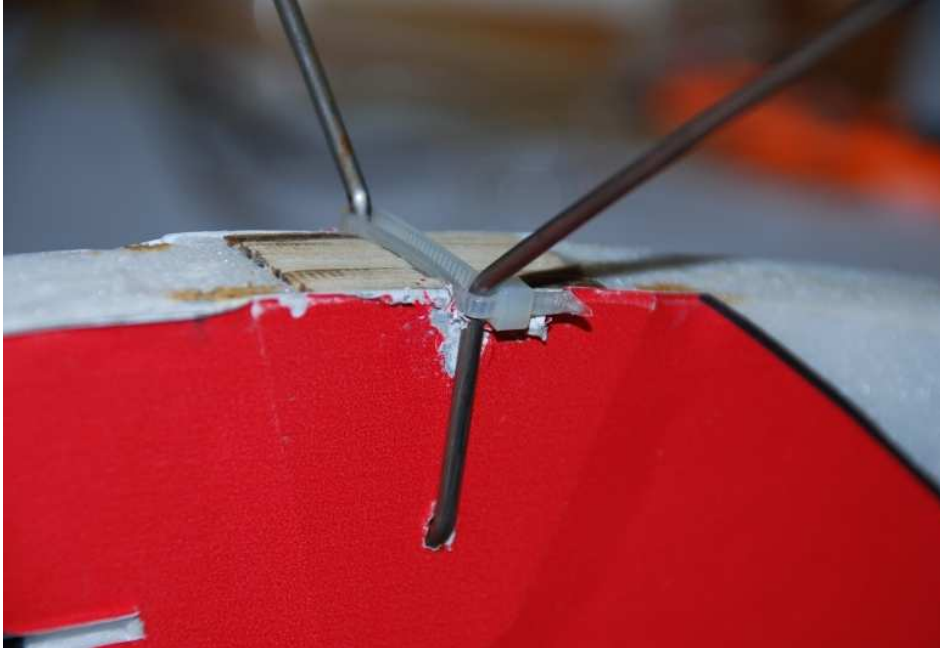

Step 42

Fit the landing gear wires into the slots in the landing gear mount and secure in place with a small electrical tie. Fit the tie into the groove on the bottom of the landing gear mount. **Tip:** Round the corners of the slots so that the wires fit flush to the mount surface.

Note: Trim the wire extension that fits into the fuselage as necessary to avoid interference.

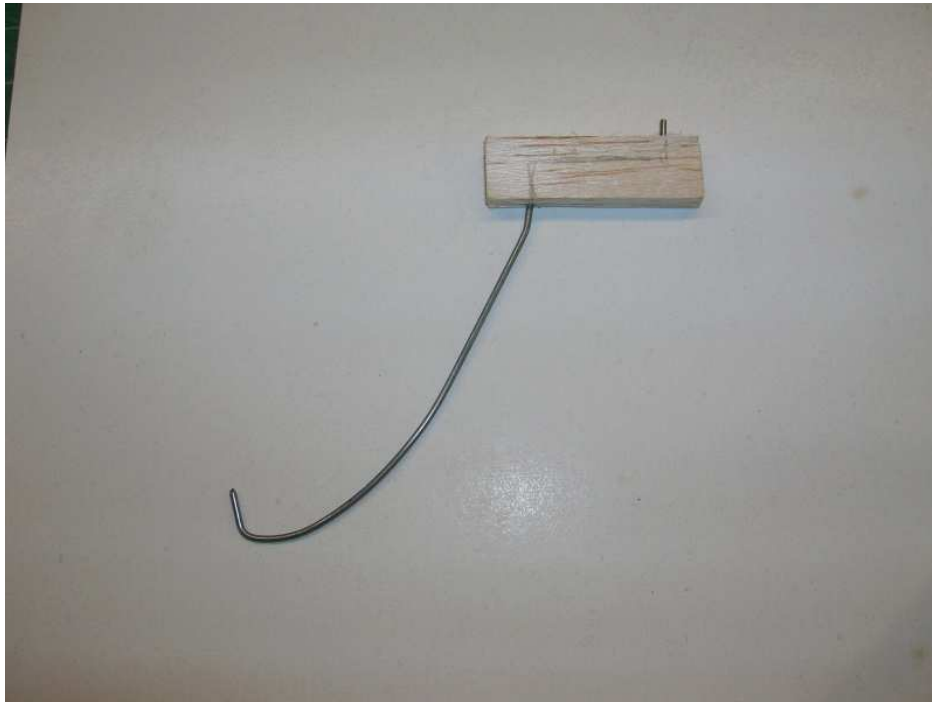

Step 43

Bend the tail wire to final shape and glue between the two tail wire mounts.

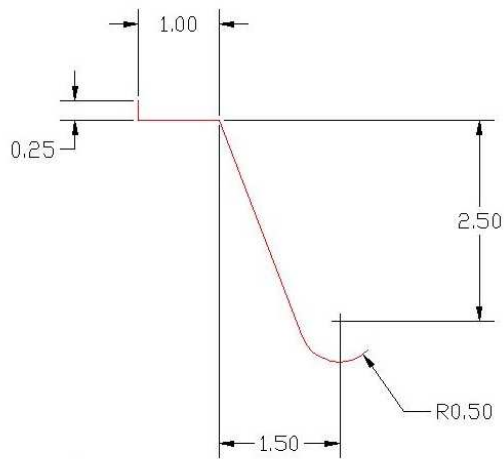

TAILSKID WIRE
.046" DIAMETER

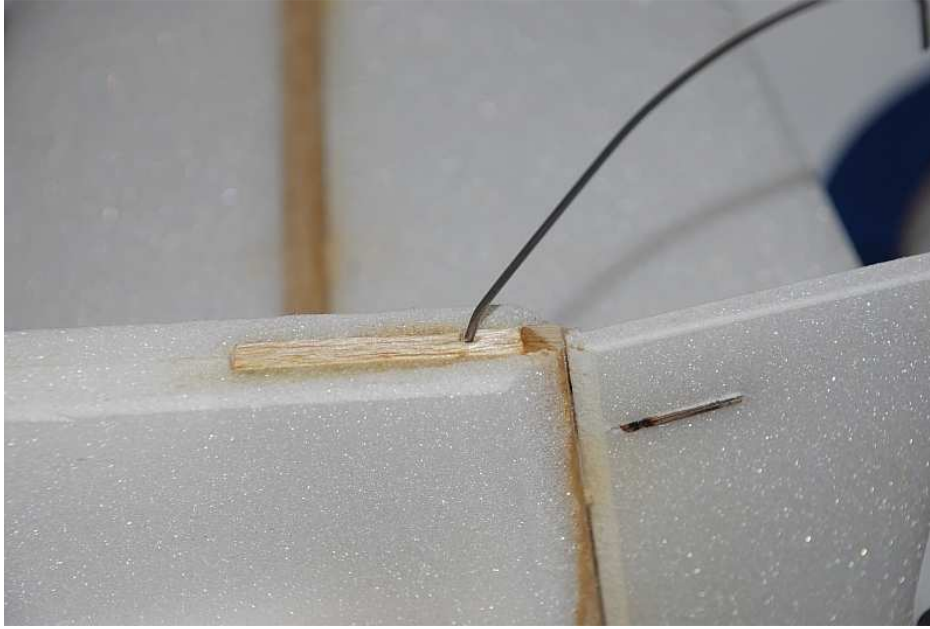

Step 44

Glue the tail skid assembly in the slot provided at the rear of the fuselage.

Motor, ESC, Servo, Receiver and Battery installation:

Aileron Servo Installation:

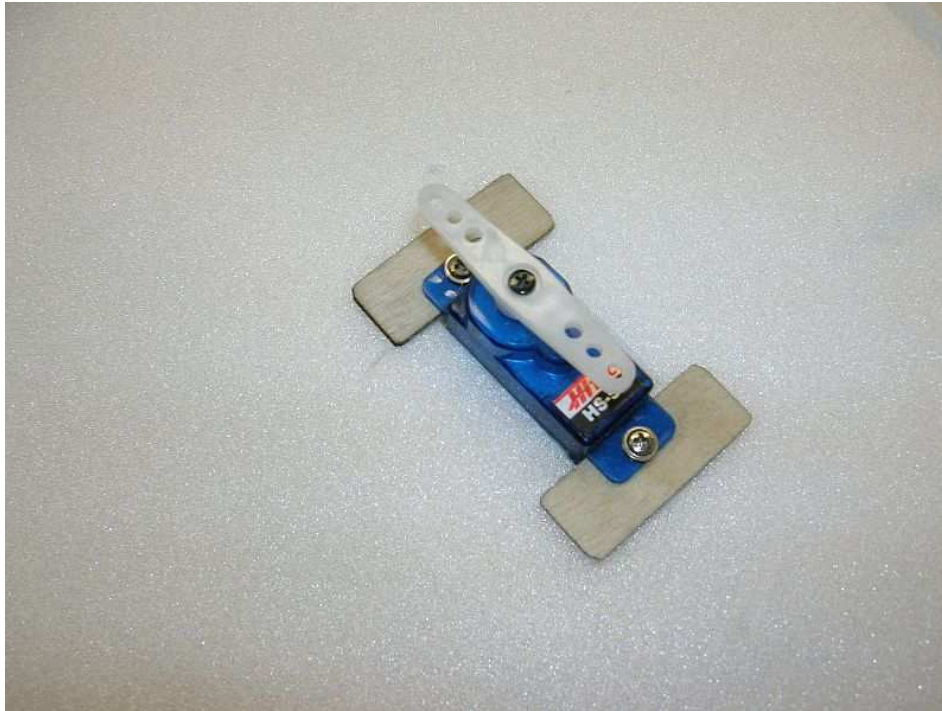

Step 45

Secure the wing servos in place with the servo mounting screws provided with the servos. Route the aileron servo leads through the interior of the wing, and out through the exit hole. **Do not over-tighten the screws as you may strip the screw holes.**



Step 46

Cut a section of carbon fiber tube to length and insert the threaded rods into each end. **Prior to insertion, it is best to rough sand the smooth end of the rods for better adhesion.** Secure with thin CA or JB Weld. Heat shrink a section of heat shrink tubing onto the end of the carbon fiber tube. Wick thin CA into the joint between the heat shrink and the rod. Install the clevis on the threaded rod leaving room for adjustment, and attach to the servo arm.

Elevator and Rudder Servo Installation:



Step 47

Securely glue the elevator and rudder servo mounts in place with medium foam safe CA.



Step 48

Insert the threaded rod into the end of the carbon fiber tube and glue with thin CA or JB Weld. Heat shrink a section of heat shrink tubing onto the end of the carbon fiber tube. Wick thin CA into the joint between the heat shrink and the rod. Install the clevis on the threaded rod leaving room for adjustment, and attach to the appropriate servo arm.



Step 49

Install the elevator and rudder push rod securing at both ends with the nylon clevises provided. Bend the rod ends as appropriate to maintain torsion free geometry.

Motor, ESC, Receiver and Battery installation



Step 50

Mount the motor using #2 wood screws and washers. Check to make sure the motor turns freely and there is no interference between the rotating motor components and the fuselage. **Tip: Right thrust adjustments can be made by placing #2 washers under the left legs of the motor mount.**

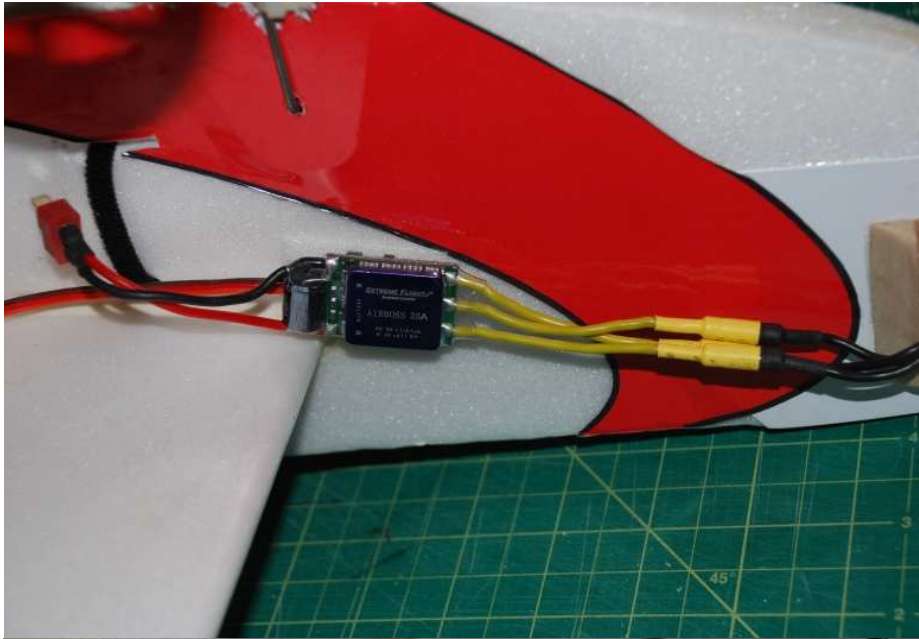

Step 51

Mount the ESC and receiver with Velcro on the left side of the fuselage as shown.

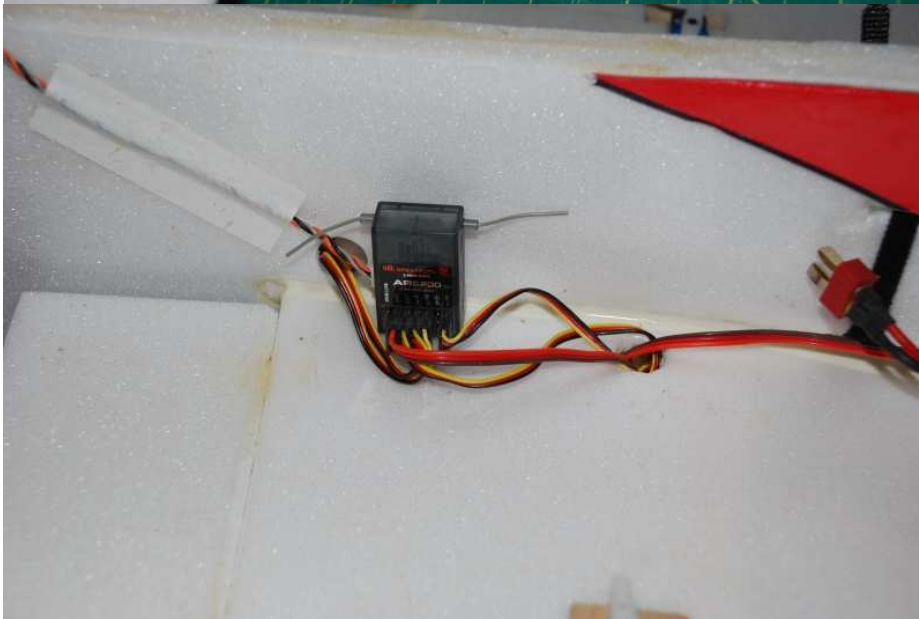

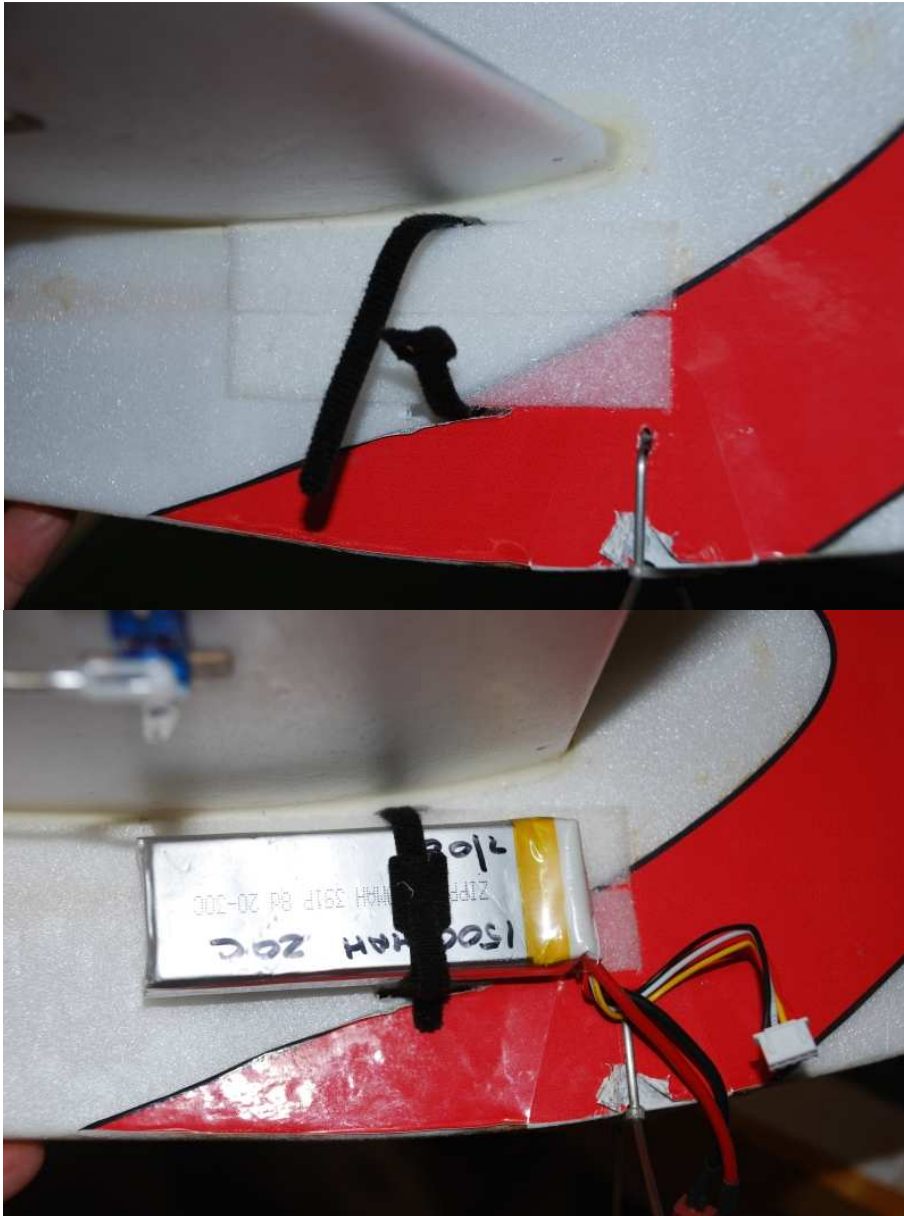

Step 52

Mount the battery with Velcro strips on the right the fuselage as shown. Use a Velcro strap through the slots in the lower crutch to secure the battery in place.

Pre-flight checklist

Balancing:

We recommend that you perform initial flights with the CG $3\frac{1}{2}$ to 4 inches behind the leading edge at the wing root. Adjust the CG to get the flight characteristics that suit your taste.

Electrical Components:

Check that all electrical components are securely attached and the all plugs are fully seated. Secured any extra length on servo leads neatly within the fuselage or the wing. Avoid loose or dangling wires. For 72 MHz systems, we recommend the use of a micro antenna such as the Azarr, or the Berg Peel & Stick Antenna.

Controls:

Check that all the control surfaces move in the correct direction. For 3D flying adjust the servos and pushrod locations to give 45° of control surface travel. If your radio has a dual rate function set the low rates to suit your taste. We recommend 30-40% expo to start.

Prior to each day's flying, always perform range check of your equipment in accordance with the manufactures instructions.

